



Tecumseh

Compresor

Código de tensión : TZ

TAG4534Y

Frío Comercial Positivo (HP)

400V 3~ 50Hz / 440V 3~ 60 Hz

R134a

AGB4534YTZ

Condiciones	Frecuencia	Potencia frigorífica nominal		Potencia sonora ISO3745 / ISO 3743-1
		Watts	BTU/h	
EN12900_MHP / R134a	50 Hz / 60 Hz	3539 / 4209	12068 / 14353	77 dBA

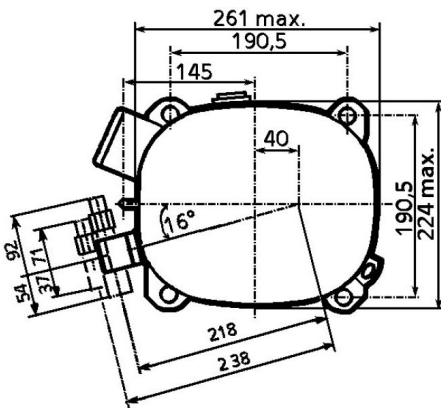
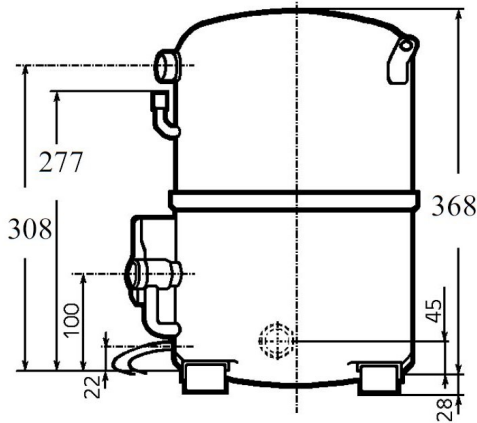

Cilindrada (cc)	100,7
Peso neto (kg)	44.0
Cantidad de aceite (cc)	1760.0
Tipo de aceite	P.O.E
Expansión	Capilar/regulador de presión
Enfriamiento	Ventilado
Fase auxiliar (Ohm)	4.3
Intensidad	
Nominal (A)	4.7 5.4
Máxima (A)	10.4 10.6
De arranque (A)	41 44
Tipo de componentes eléctricos	TRI
Protector	Interne
Diámetro exterior del tubo	
Ø del tubo de aspiración	22.2 (7/8")
Ø del tubo de descarga	15.9 (5/8")
Ø del tubo de carga	6.35 (1/4")

* EN12900_MHP : T°Cond. 45.0°C / T°Evap. -10.0°C / T°Gases Aspirados. 20.0°C
T°Subenfriamiento. 0.0K

Homologaciones :



Tecumseh se reserva el derecho de modificar la información contenida en este documento sin preaviso



Tecumseh

TAG4534Y	Tension TZ : 400V 3~ 50Hz / 440V 3~ 60 Hz
-----------------	--

Les performances sont données dans les **conditions EN12900_MHP** :
 Condition Dew
 The performance data are in **EN12900_MHP conditions** :
 Dew Condition

Gaz aspirés : 20.0 °C
 Sous refroidissement : 0.0 K
 Return gas : 20.0 °C
 Subcooling : 0.0 K

© 2021 Tecumseh Products Company
All rights reserved

50 Hz R134a

N°217EU-T

4 T condensation	5 T évaporation	(°C)	-25	-20	-15	-10	-5	0	5	10	15
30	1 P frigorifique	(Watt)	1673	2368	3368	4659	6228	8064	10154	12486	15049
	2 P absorbée	(W)	799	1121	1410	1664	1884	2070	2222	2340	2423
	3 I absorbée	(A)	2.53	2.92	3.27	3.59	3.86	4.09	4.28	4.42	4.53
40	1 P frigorifique	(Watt)	1372	1942	2793	3913	5287	6901	8744	10802	13062
	2 P absorbée	(W)	783	1112	1420	1706	1972	2216	2440	2642	2823
	3 I absorbée	(A)	2.52	2.91	3.28	3.63	3.95	4.25	4.53	4.79	5.02
50	1 P frigorifique	(Watt)		1512	2216	3165	4344	5739	7337	9123	11082
	2 P absorbée	(W)		1103	1430	1749	2060	2363	2658	2945	3224
	3 I absorbée	(A)		2.90	3.29	3.67	4.05	4.42	4.79	5.15	5.51
60	1 P frigorifique	(Watt)			1636	2415	3401	4579	5934	7450	9113
	2 P absorbée	(W)			1440	1791	2148	2509	2876	3248	3624
	3 I absorbée	(A)			3.30	3.72	4.15	4.59	5.05	5.52	6.01

60 Hz R134a

N°217EU-T

4 T condensation	5 T évaporation	(°C)	-25	-20	-15	-10	-5	0	5	10	15
30	1 P frigorifique	(Watt)	1949	2809	4011	5540	7383	9524	11951	14650	17607
	2 P absorbée	(W)	889	1298	1666	1991	2275	2517	2718	2877	2994
	3 I absorbée	(A)	2.31	2.74	3.14	3.52	3.87	4.19	4.49	4.77	5.01
40	1 P frigorifique	(Watt)	1593	2301	3327	4653	6266	8151	10291	12674	15283
	2 P absorbée	(W)	873	1288	1677	2041	2381	2695	2984	3248	3487
	3 I absorbée	(A)	2.32	2.73	3.15	3.56	3.97	4.37	4.77	5.16	5.55
50	1 P frigorifique	(Watt)		1790	2639	3764	5150	6778	8635	10704	12968
	2 P absorbée	(W)		1278	1689	2092	2487	2873	3251	3620	3981
	3 I absorbée	(A)		2.73	3.16	3.60	4.06	4.54	5.04	5.55	6.09
60	1 P frigorifique	(Watt)			1948	2873	4032	5408	6984	8742	10665
	2 P absorbée	(W)			1701	2143	2593	3051	3518	3992	4476
	3 I absorbée	(A)			3.17	3.64	4.16	4.71	5.31	5.95	6.62

1 = cooling capacity 2 = power input 3 = current 4 = condensing temperature 5 = evaporating temperature

Nota : Tecumseh se réserve le droit de modifier les informations contenues dans ce document sans préavis.

Note : Tecumseh reserves the right to change information contained in this document without notification.